

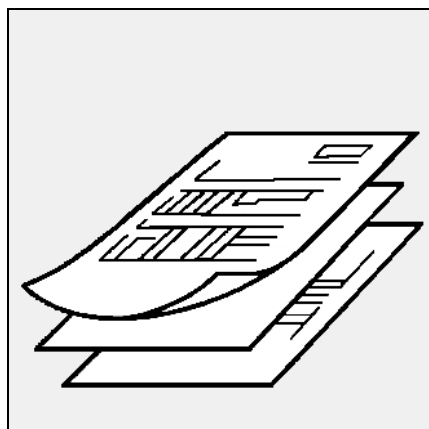

NC9 GX207/8



Données techniques
Brûleurs gaz..... 2-7



Dati tecnici
Bruciatori di gas 2-7



Datos técnicos
Quemadores de gas 2-7



Technical data
Gas burners 2-7



Technische Daten
Gasgenbläsebrenner..... 2-7



Технические характеристики
на газовые горелки 2-7



Pièces de rechange
Pezzi di ricambio
Piezas de recambio
Spare parts list
Ersatzteilliste
Запасные части..... 9-14



Schémas électrique et hydraulique
Schemi elettrico e idraulico
Esquema eléctrico y hidráulico
Electric and hydraulic diagrams
Elektro- und Hydraulikschema
Электрические и гидравлические схемы 15-18



Principaux composants / Caractéristiques d'utilisation
Componenti principali / Caratteristiche d'impiego
Componentes principales / Características de utilización
Main components / Characteristics of use
Wichtigste Komponenten / Betriebsdaten
Основные компоненты / Рабочие характеристики

Principaux composants:

- Coffret de commande et sécurité : SG 513
- Détecteur de flamme : Sonde d'ionisation
- Moteur de ventilation : monophasé 230V, 50Hz, 85W 2840 tr/min, condensateur: 3µF/440V
- Turbine de ventilation : Ø133x62
- Transformateur d'allumage : EBI 1 x 11kV
- Manostat d'air : LGW 3 C3
- Commande volet d'air : servomoteur STA 5

Componenti principali

- Programmatore di comando e di sicurezza: SG 513
- Rilevatore di fiamma: Sonda di ionizzazione
- Motore del ventilatore: monofase 230V, 50Hz, 85W 2840 giri/min, condensatore: 3µF/440V
- Turbina del ventilatore: Ø133x62
- Trasformatore d'accensione: EBI 1 x 11kV
- Manostato aria: LGW 3 C3
- Comando serranda aria: servomotore STA 5

Principales componentes

- Cajetín de control y seguridad: SG 513
- Detector de llama: Sonda de ionización
- Motor de ventilación: monofásico 230V, 50Hz, 85W 2840 t/min, condensador: 3µF/440V
- Turbina de ventilación: Ø133x62
- Transformador de encendido: EBI 1 x 11kV
- Manóstató de aire: LGW 3 C 3
- Control de la trampilla de aire: STA 5

Caractéristiques d'utilisation

Température ambiante :

- d'utilisation: - 5... 40°C
- de stockage: - 20... 70°C

Tension / Fréquence :

- 230 VAC -15...+10% - 50Hz±1% monophasé

Degré de protection : IP 21



Dans le cas d'une alimentation électrique sans neutre à la terre, installer un transformateur d'isolement de 2,0 A/400 VA.

Caratteristiche d'impiego

Temperatura ambiente:

- d'utilizzazione: - 5... 40°C
- di stoccaggio: - 20... 70°C

Tensione / Frequenza:

- 230VAC -15...+10% - 50Hz±1% monofase

Grado di protezione: IP 21



In caso di alimentazione elettrica senza neutro collegato a terra, installare un trasformatore d'isolamento di 2,0 A/400 VA.

Características de utilización

Temperatura ambiente:

- de utilización: - 5... 40°C
- de almacenamiento: - 20... 70°C

Tensión eléctrica / Frecuencia:

- 230 VAC -15...+10% - 50 H±1% monofásico

Grado de protección: IP 21



En caso de alimentación eléctrica sin neutro a tierra instalar un transformador de aislamiento de 2,0 A/400 VA.

Principaux composants / Caractéristiques d'utilisation
Componenti principali / Caratteristiche d'impiego
Componentes principales / Características de utilización
Main components / Characteristics of use
Wichtigste Komponenten / Betriebsdaten
Основные компоненты / Рабочие характеристики

Main components

- Control and safety unit:
SG 513
- Flame detector:
ionisation probe
- Fan motor:
single-phase 230V, 50Hz,
8W 2840 rpm, capacitor:
3µF/440V
- Ventilation turbine
Ø133x62
- Firing transformer:
EBI 1 x 11kV
- Air pressure switch:
LGW 3 C3
- Air flap control:
servomotor STA 5

Wichtigste Komponenten:

- Feuerungsautomat:
SG 513
- Flammenüberwachung:
Ionisationssonde
- Gebläsemotor:
einphasig 230V, 50Hz,
85W 2840 min⁻¹, Kondensator:
3µF/440V
- Lüfterrad:
Ø133x62
- Zündtrafo:
EBI 1 x 11 kV
- Luftdruckwächter:
LGW 3 C3
- Luftklappensteuerung:
Stellantrieb STA 5

Основные компоненты

- Прибор управления:
SG 513
- Контроль факела:
ионизационный зонд
- Двигатель воздуходувки:
однофазный 230 В, 50 Гц,
85 Вт 2840 мин⁻¹, конденсатор:
3 мкФ / 440 В
- Колесо вентилятора:
Ø133x62
- Трансформатор розжига:
EBI 1 x 11 кВ
- Реле давления воздуха:
LGW 3 C3
- Управление воздушной заслонкой:
серводвигатель STA 5

Characteristics of use

- Ambient temperature :
- for use : - 5... 40°C
 - for storage : - 20... 70°C
- Voltage / Frequency:
- 230VAC -15...+10% - 50Hz±1%
- single-phase

Protection level :IP 21



With an electrical power supply without an earthed neutral, install a 2.0 A/400 VA isolation transformer

Betriebsdaten

- Umgebungstemperatur:
- Betriebstemperatur:- - 5... 40°C
 - Lagerungstemperatur: - 20... 70°C
- Spannung/Frequenz:
- 230 VAC -15...+10% - 50Hz±1%
- einphasig

Schutzart: IP 21



Bei einer Stromversorgung ohne geerdeten Nullleiter einen Isoliertrafo mit 2,0 A/400 VA installieren.

Рабочие характеристики

- Температура окружающей среды:
- Рабочая температура: 5...40°C
 - Температура хранения: -20...70°C
- Напряжение / частота:
- 230 В переменный ток
 - 15...+10% - 50 Гц±1% однофазный
- Вид защиты: IP 21



При электропитании без заземленной нейтрали смонтируйте изоляционный трансформатор с 2,0 А / 400 ВА.

Courbes de puissance
Curve di potenza
Diagramas de potencia
Power graphs
Arbeitsfelder
Рабочие поля

Composition de la rampe gaz
Composizione della rampa gas
Composición de la rampa de gas
Gas manifold composition
Zusammensetzung der Gasarmatur
Составляющие газовой арматуры

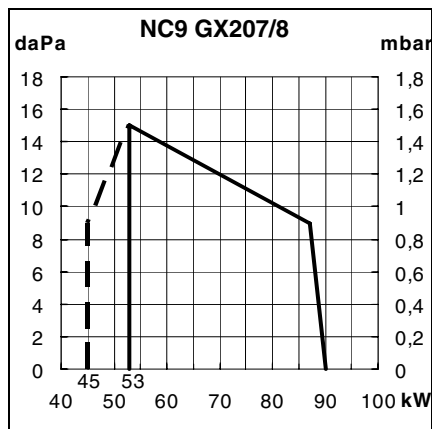

Brûleur Bruciatore Queimador Burner Brenner Горелка	Gaz Gas Gas Gas Gas Газ	P gaz P Gas P Gas P Gas P Gas P Plin	P max P макс.	Vanne Valvola Válvula Valve Ventil Клапан		Contrôleur étanchéité Controllore tenuta Control. estanqueidad Leakage test unit Dichtheitskontroll Контроль плотности	Filtre Filtro Filtro Filter Filter Фильтр			Manostat Manostato Manóstato Press. Switch Druckwächter Реле давления
				MB- ZRDLE...	Ø bride Ø flangia Ø brida Ø flange Ø Flansch Ø фланец Rp		Intégré Incorp. Integrado Interner внутр. FI	extérieur externo external externer наружн. Rp	poche tasca bolsa pocket Taschen карман. FP	
NC9 GX 207	G20	20	90	407	3/4	FI				150A5
		300								
	G25	25								
		300								
NC9 GX 208	G31	37								
		148								

Type Tipo Tipo Tipo Type Art Тип	Groupe Gruppo Grupo Group Gruppe Группа	Pression de distribution Pressione di distribuzione Presión de distribución Distribution pressure Eingangsdruk Давление на входе			Hi à 0°C et 1013 mbar Hi a 0°C e 1013 mbar Hi à 0°C y 1013 mbar Hi at 0°C and 1013 mbar Hi bei 0°C und 1013 mbar Hi при 0°C и 1013 мбар		Gaz Gas Gas Gas Gas Газ
		Pn мбар	Pmin мбар	Pmax мбар	мин. (кВтч/м³)	макс. (кВтч/м³)	
Gaz H Gas H Газ H	2H	20 300	17 240	25 360	9,5	11,5	G20
Gaz L Gas L Газ H	2L	20 25 300	17 20 240	25 30 360	8,5	9,5	G25
Gaz P Gas P Газ P	3P	37 148	25 120	45 180	24,5	26,5	G31

Puissance kW Potenza kW Potencia kW Power kW Leistung kW Мощность кВт	NC 9GX207/8	
	min	max
Brûleur (kW)	53	90
Min. allumage (kW)	45	--
Générateur (kW)	49	83
Débit nominal réel de gaz à 15°C et 10 13 mbar		
Naturel groupe G20 Hi = 9,45 m ³ /h (kW h/m ³)	5,6	9,5
Naturel groupe G25 Hi = 8,13 m ³ /h (kW h/m ³)	6,5	11,1
Propane groupe G31 Hi = 24,44 m ³ /h (kW h/m ³)	2,2	3,7
Massa volumica kg/m ³ = 1,98		
Bruciatore (kW)	53	90
Min. accensione (kW)	45	--
Generatore (kW)	49	83
Portata nominale eff. di gas a 15°C e 10 13 mbar		
Naturale gruppo G20 Hi = 9,45 m ³ /h (kW h/m ³)	5,6	9,5
Naturale gruppo G25 Hi = 8,13 m ³ /h (kW h/m ³)	6,5	11,1
Propano G31 Hi = 24,44 m ³ /h (kW h/m ³)	2,2	3,7
Massa volumica kg/m ³ = 1,98		
Queimador (kW)	53	90
Min. encendido (kW)	45	--
Generador (kW)	49	83
Caudal nominal real de gas a 15°C y 10 13 mbar		
Natural grupo G20 Hi = 9,45 m ³ /h (kW h/m ³)	5,6	9,5
Natural grupo G25 Hi = 8,13 m ³ /h (kW h/m ³)	6,5	11,1
Propano G31 Hi = 24,44 m ³ /h (kW h/m ³)	2,2	3,7
Densidad kg/m ³ = 1,98		
Burner (kW)	53	90
Min. ignition (kW)	45	--
Generator (kW)	49	83
Actual gas flow rate at 15°C and 10 13 mbar		
Natural group G20 Hi = 9.45 m ³ /h (kW h/m ³)	5,6	9,5
Natural group G25 Hi = 8.13 m ³ /h (kW h/m ³)	6,5	11,1
Propane G31 Hi = 24.44 m ³ /h (kW h/m ³)	2,2	3,7
Voluminal mass kg/m ³ = 1,98		
Brenner (kW)	53	90
Min. Zündleistung (kW)	45	--
Kessel (kW)	49	83
Effektiver Gasdurchsatz bei 15°C und 10 13 mbar		
Erdgas Gruppe G20 Hi = 9,45 m ³ /h (kW h/m ³)	5,6	9,5
Erdgas Gruppe G25 Hi = 8,13 m ³ /h (kW h/m ³)	6,5	11,1
Flüssiggas Gruppe G31 Hi = 24,44 m ³ /h (kW h/m ³)	2,2	3,7
Dichte kg/m ³ = 1,98		
Горелка (кВт)	53	90
Мин. мощность розжига (кВт)	45	--
Котел (кВт)	49	83
Эффект. расход газа при 15°C и 1013мбар		
Прир. газ группы G20 Hi = 9,45 м ³ /ч (kW h/m ³)	5,6	9,5
Прир. газ группы G25 Hi = 8,13 м ³ /ч (kW h/m ³)	6,5	11,1

Encombremet Dimensions
Dimensioni d'ingombro
Dimensiones Medidas
Space requirements and dimensions
Maßbild und Abmessungen
Чертеж с размерами

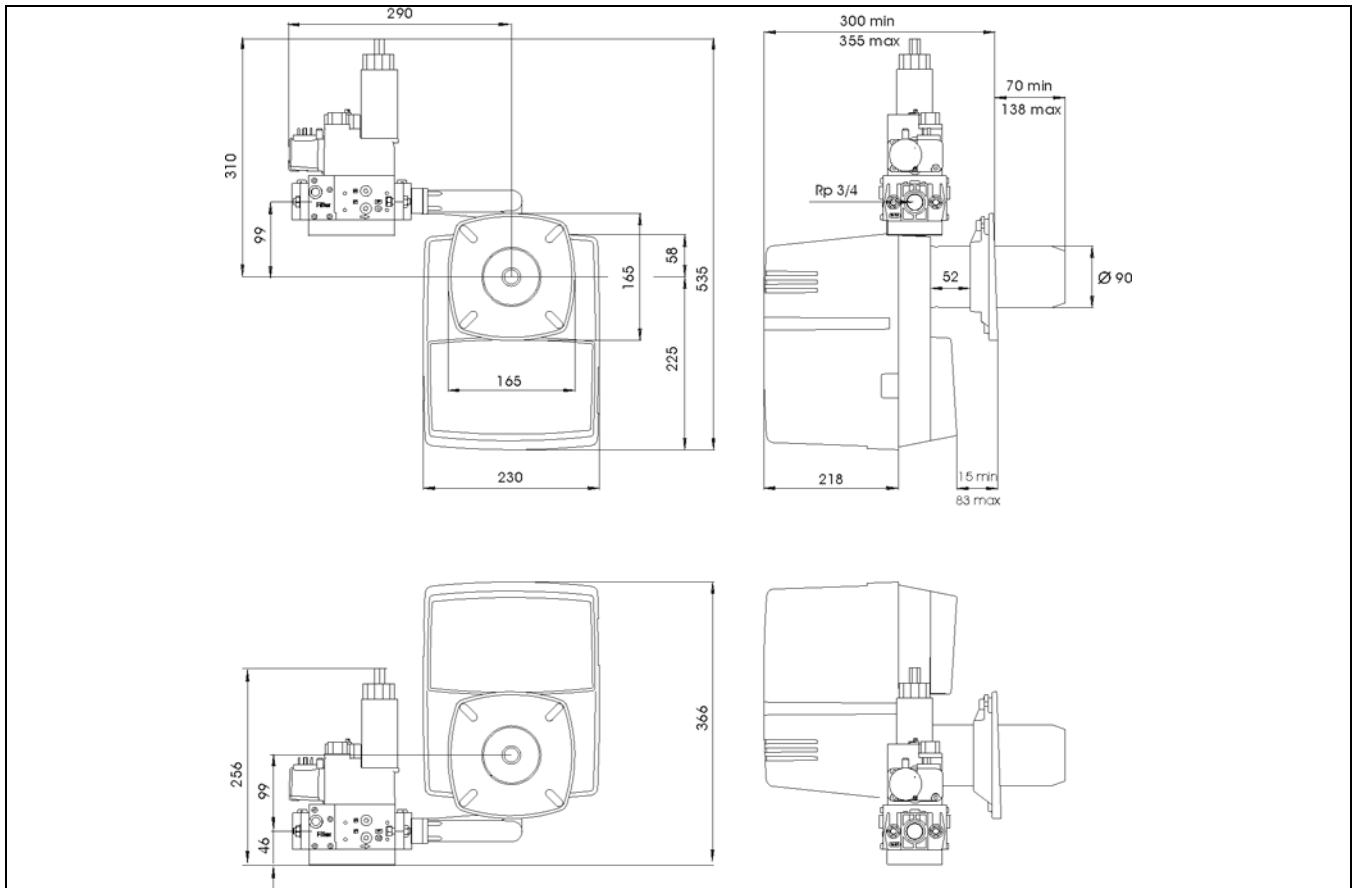

Encombremet Dimensions Dimensioni d'ingombro Dimensiones Medidas Space requirements and dimensions Maßbild und Abmessungen Чертеж с размерами

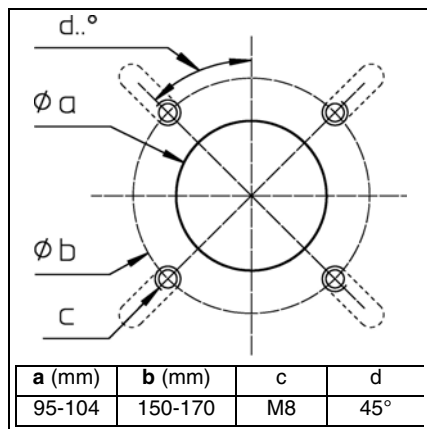

Dimensiones y medidas

Respetar una distancia libre mínima de 0,6 metros a ambos lados del quemador para permitir las operaciones de mantenimiento.

Ventilación calentador

El volumen de aire nuevo requerido es de 1,2 m³/kWh producido en el quemador.

Rampa de gas

Sólo se coloca en horizontal a la derecha o a la izquierda.

Чертеж с размерами

Для теххода с каждой стороны горелки должно быть оставлено свободное место как минимум 0,6 м.

Вентиляция котельного помещения

Подача свежего воздуха должна составлять 1,2 м³/кВтч мощности горелки.

Газорегулирующая арматура

Возможен горизонтальный монтаж справа или слева.

Encombremet et dimensions

Respecter une distance libre minimum de 0,6 mètre de chaque côté du brûleur pour permettre les opérations de maintenance.

Ventilation chaufferie

Le volume d'air neuf requis est de 1,2 m³/kWh produit au brûleur.

Rampe gaz

S'implante uniquement à l'horizontale à droite ou à gauche.

Space requirements and dimensions

Leave a space of at least 0.6 metres on each side of the burner for maintenance purposes.

Boiler-house ventilation

Volume of fresh air required is 1.2 m³/kWh produced at the burner.

Gas manifold

Can only be installed horizontally, on the right or on the left.

Dimensioni d'ingombro

Lasciare uno spazio libero minimo di 0,6 metri su ogni lato del bruciatore per consentire le operazioni di manutenzione.

Ventilazione locale caldaia

La portata dell'aria di ricambio del locale deve essere almeno di 1,2 m³/kWh bruciatore.

Rampa gas

Deve essere installata unicamente in orizzontale a destra o a sinistra.

Maßbild und Abmessungen

Für Servicearbeiten ist ein freier Abstand von min. 0,6 m auf jeder Seite des Brenners sicherzustellen.

Heizraumbelüftung

Die nötige Frischluftzufuhr beträgt 1,2 m³/kWh am Brenner.

Gasarmaturgruppe

Montage waagrecht rechts oder links möglich.



**Pièces de rechange
Pezzi di ricambio
Piezas de recambio
Spare parts list
Ersatzteilliste
Запасные части**

NC9 GX207/8



NC9 GX 207/8	13 013 671



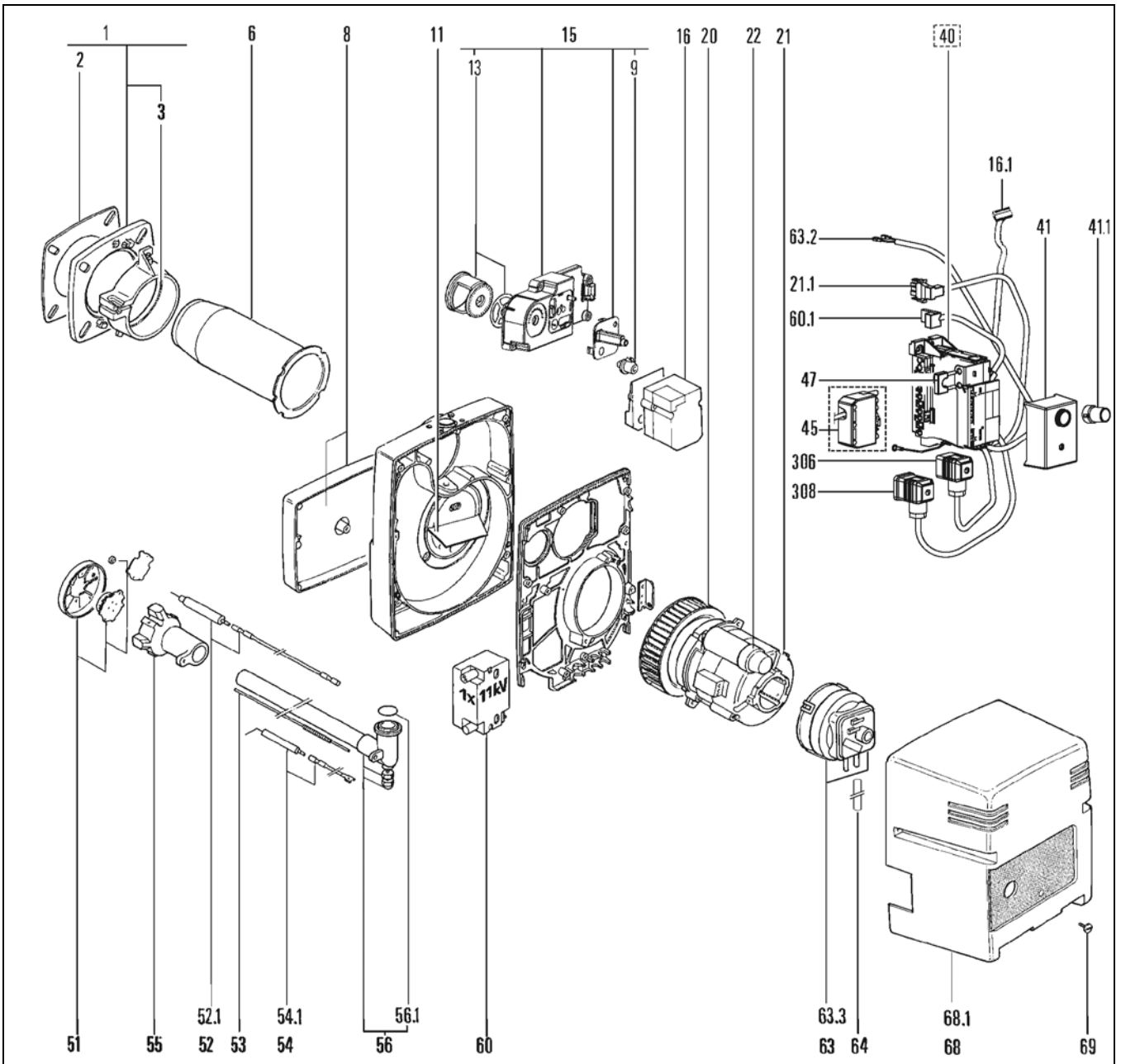

Pos.	Désignation	Denominazione	Designación	Description	Bezeichnung	Название	Art. Nr.
1	Access. Chaudière	Accessori caldaia	Accesorios caldera	Boiler accessories	Anschlußflansch BG	Комплектующие котла	13 015 506
2	Joint façade Ø90	Guarnizione	Junta	Flange seal	Isolierflansch	Фланец	13 010 502
4	Eurobride monté Ø90	Flangia	Abrazadera	Euroflange cpl.			13 010 504
4.1	Joint tressé Ø90	Giunta	Junta	Braided seal			13 011 149
6	Embout Ø68/78/90	Imbufo	Cañón	Blast tube	Brennerrohr	Жаровая труба	13 007 733
8	Boîte à air	Coperchio	Caja de aire	Air damper cover	Luftkasten	Крышка воздушной заслонки	13 010 506
9	Commande manu. volet air	Com. manu. serranda aria	Mando manual valv. de aire	Manu. control air flap			13 010 509
11	Recyclage d' air ass.	Riciclaggio aria	Diaphragma de aire	Recycling air	Ansaugluftführung	Рециркуляция воздуха	13 010 513
13	Volet d'air + Ressort	Serranda aria + molla	Valv.de aire + muelle	Air flap + Spring	Luftklappe	Воздушная заслонка	13 016 896
15	Kit tableau de bord	Set registro d'aria	Set compuerta de aire	Set control panel	Luftleitgehäuse-Set	Набор панели управления	13 016 894
16	Servomoteur	Servomotore	Servomotor	Air flap servomotor	Stellantrieb	Серводвигатель	
20	Turbine Ø133x62	Turbina	Ventilat Turbinaor	Air fan	Ventilatorrad	Вентилятор	13 010 517
21	Moteur	Motore	Motor	Motor	Motor	Двигатель	13 010 518
21.1	Câble moteur	Cavo motore	Cable/ motor	Cable f. motor			13 010 519
22	Condensateur	Condensatore	Condensador	Condensator	Kondensator	Конденсатор	13 010 520
40	Cassette raccord.	Cassette di collegamento	Casete de conexión	Elec. connection box	Steckerbahnhof	Клеммная коробка	13 010 521
41.1	Bouton rallonge	Bottone/ programmatore	Torta/ cajetín de control	Ext. piece / control unit	Verlängerung / Entstöckknopf	Кнопка	13 010 964
45	Prise Wieland mâle 7P	Presa Wieland masc. 7P	Toma 7P	Wieland plug 7P	Wieland Stecker 7P/ Kessel.	Штекер 7 п. Wieland	13 010 523
47	Pont d'ionisation	Ponte di ionizzazione	Puente de ionización	Ionisation bridge	Verbindungsstecker	Ионизационный мост	13 010 524
51	Ensemble déflecteur Ø74,5/0-8FD	Set deflettore	Set deflector	Turbulator set	Stauscheibe	Турбулятор	13 007 727
52	Electrode allu.	Elettrodo di accensione	Electrodo d'encendido	Ignition electrode	Zündelektrode	Электрод розжига	13 010 528
52.1	Câble allu.	Cavo di accensione	Cable de encendido	Ignition cable	Zündkabel	Кабель розжига	13 010 525
53	Tige de réglage	Asta di regolazione	Vástago d'ajuste	Adjust linkage	Verstellspindel	Регулировочный стержень	13 010 527
54	Sonde ionisation	Sonda di ionizzazione	Sonda de ionización	Ionisation probe	Ionisationssonde	Ионизационный зонд	13 010 529
54.1	Câble ionisation	Cavo ionizzazione	Cable ionización	Ionisation cable	Ionisationskabel	Кабель ионизационного	13 010 530
55	Etoile répart. gaz	Ripartitore gas	Estrella gas	Star gas head	Sterngaskopf	Звездочка	13 010 532
56	Coude gaz avec tube	Tubo adduzione gas	Gas tubo	Lance gas head	Gasrohr	Газовое колено + труба	13 010 533
56.1	Joint O'Ring	Giunto O'Ring	Junta O'Ring	O'Ring	O'Ring	Кольцевой уплотнитель	13 010 534
60	Transformateur allu. 1x11kV	Trasformatore d'accensione	Transformador de encendido	Ignition transformer	Zündtrafo	Трансформатор розжига	13 007 816
60.1	Câble transformateur	Cavo trasformatore	Cable transformador	Cable transformer	Kabel m . Stecker./ Zündtrafo	Разъем С.2-полюсный + кабель/трансформатор.	13 010 535
63	Pressostat LGW3C3	Pressostato	Pressostato	Press. contr. device	Luftdruckwächter	Регулятор	13 010 536
63.2	Câble / pressostat	Cavo / pressostato	Cable / pressostato	Cable / press. contr.	Kabel Luftdruckwächter	Кабель воздушного регулятора	13 010 537
63.3	Support pressostat	Supporto pressostato	Soporte pressostato	Press. contr. device stand	Halter / Luftdruckwächter	Кронштейн регулятора	13 007 18



Pos.	Désignation	Denominazione	Designación	Description	Bezeichnung	Название	Art. Nr.
64	Tuyau PVC Ø 6/8	Tubetto PVC	Tubo PVC	PVC tube			1 3010 538
68	Capot	Coperchio	Tapa	Cover	Haube	Крышка	13 023 351
68.1	Plaqueette frontale standard	Tharghetta frontale	Placa frontal	Standard front cover	Typenplatte	Передняя плитка	13 010 951
69	Vis / capot	Vite / coperchio	Tornillo / tapa	Oval head screw	Schraube / Haube	ВИНТ	13 007 853

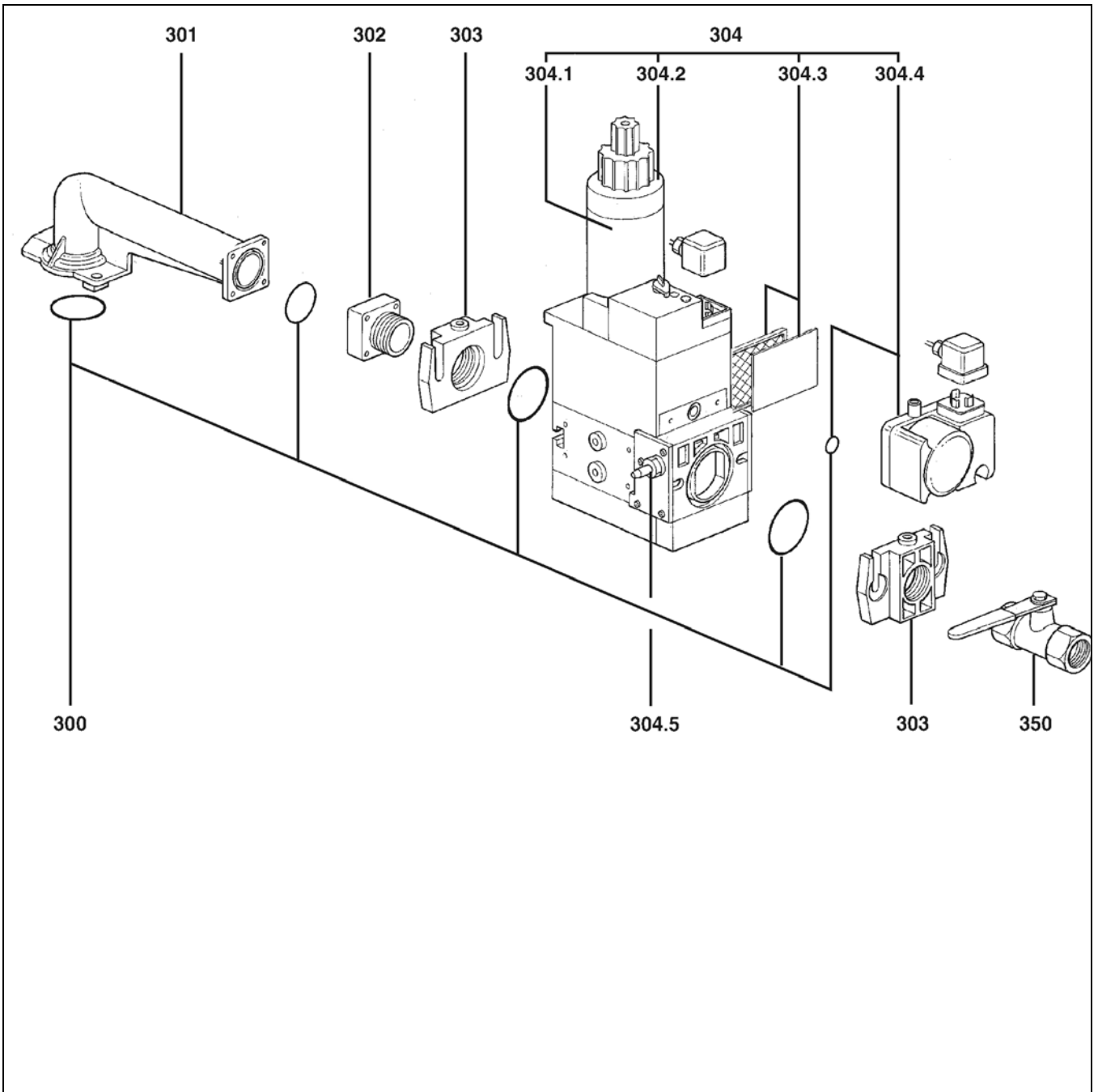

Pos.	Désignation	Denominazione	Designación	Description	Bezeichnung	Название	Art. Nr.
	Rampe gas MBZRDLE 407 B01 S20	Rampa gas MBZRDLE 407 B01 S20	Rampa de gas MBZRDLE 407 B01 S20	Gas valve assembly MBZRDLE 407 B01 S20	Gasarmatur-BG	Газовая рампа	
300	Kit joints	Set O'Ring	Set O'Ring	O'Ring set	O'Ring set	Кольцо круглого сечения / фланец	13011519
301	Collecteur	Collettore	Colector	Flange	Gasanschlussrohr Kpl.	Коллектор в сборе	13010952
302	Bride intermediaire	Flangia	Brida	Adaptation flange	Flansch	Фланец	13012203
303	Bride Rp 3/4	Flangia	Brida	Flange	Flansch	Фланец	13010074
304	Vanne MB ZRDLE 407 B01	Valvola MB ZRDLE 407 B01	Válvula MB ZRDLE 407 B01	Valve MB ZRDLE 407 B01	Gasventil MB ZRDLE 407 B01	Задвижка основного обмена и	13010071
304.1	Bobine VS N°110	Bobina	Bobina	Magnetic coil	Magnetspule	Катушка	13010072
304.2	Temporisateur Hydraulique	Temporisatore idrolico	Temporizador hidráulico	Hydr. retarder			13010081
304.3	Filtre	Filtro	Filtro	Screen	Gasfilter	Сетчатый фильтр	13010076
304.4	Pressostat	Pressostato	Presostato	Press. contr. device	Druckwächter	Регулятор	13009696
304.5	Prise de pression R1/8	Presa di pressione	Toma de presión	Pressure take off 1/8			13009722
306	Cable manostat gaz						13015642
350	Vanne manu. Rp 3/4	Rubinetto intercet. gas	Válvula manual	Shutting valve			13010970



Schémas électrique et hydraulique
Schemi elettrico e idraulico
Esquema eléctrico y hidráulico
Electric and hydraulic diagrams
Elektro- und Hydraulikschemata
Электрические и гидравлические схемы

NC9 GX207/8



NC9 GX 207/8	13 013 671

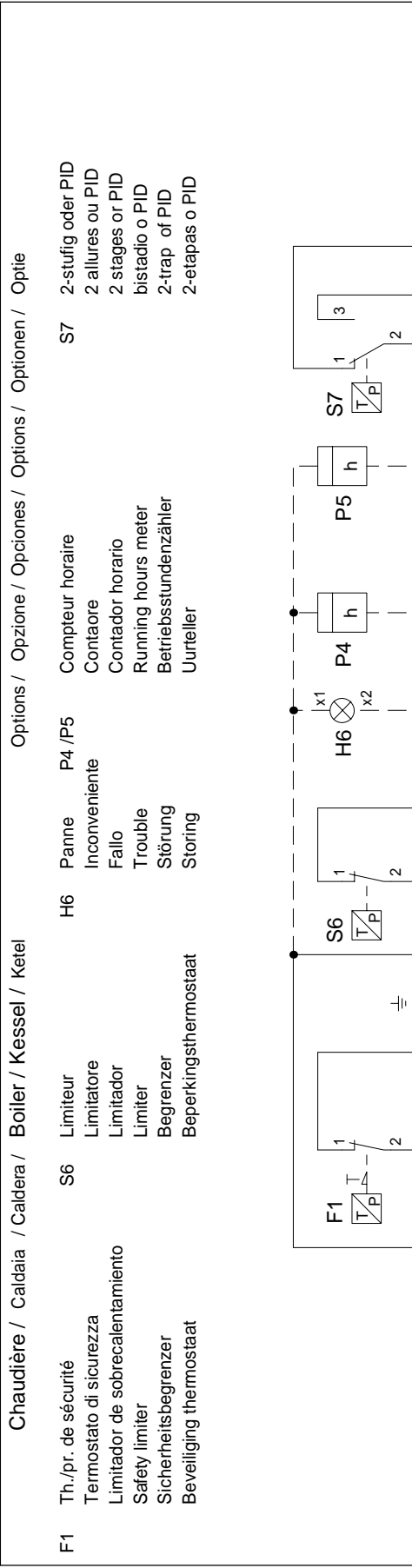

230 V~ 50Hz
L N PE

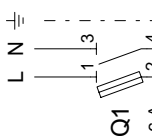

Mise à la terre conformément au réseau local
Messa a terra in conformità alla rete locale
Puesta a tierra en conformidad con la red local
Earthing in accordance with local regulation
Erdung nach örtlichen Vorschriften
Aarding in overeenstemming met het plaatselijk net

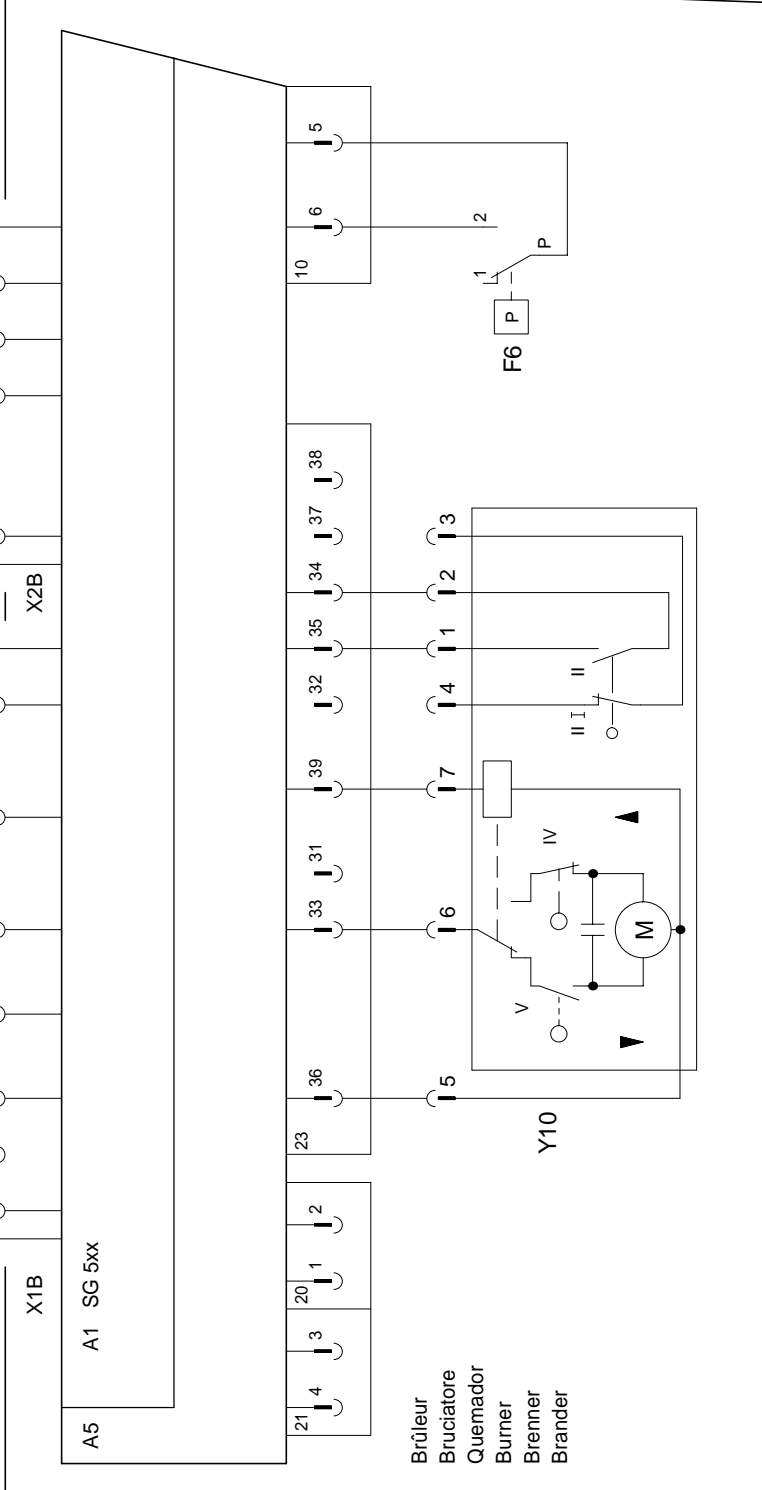

La protection de l'installation doit être conforme aux normes en vigueur.
La protezione dell'installazione deve essere in conformità alle norme in vigore.
La protección de la instalación debe ser en conformidad con las normas en vigor.
Protection of the installation must comply with the actual norms.
Der Schutz der Anlage muss den geltenden Normen entsprechen.
Bescherming van de installatie moet in overeenstemming volgens de normen die van kracht zijn.

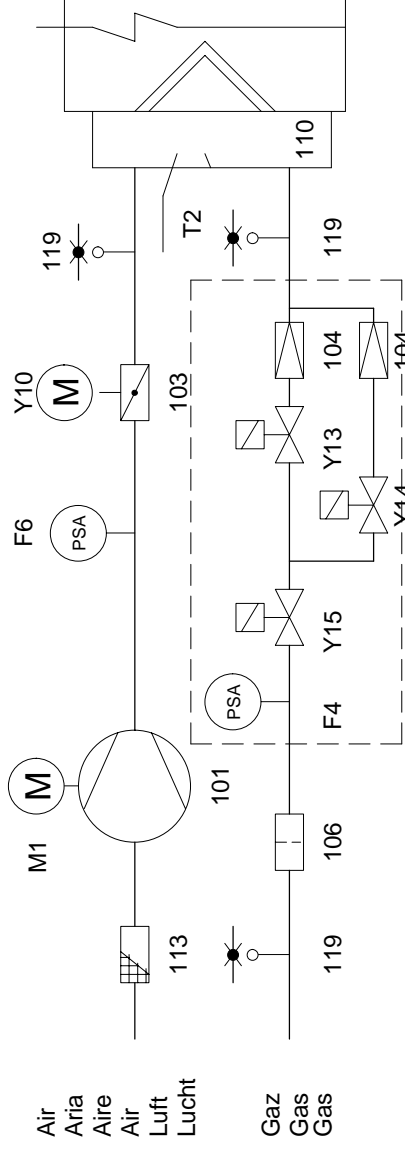

	1	2	3	4	5	6	7	8
A1	Coffret de contrôle	Programmatore di comando	Caja de mando y seguridad	Control and safety unit	Feuerungsautomat	Bedienings en veiligheidskoffer		
A5	Cassette de raccordement	Cassetta di collegamento	Casete de conexión	Connection cartridge	AnschluBkasten	Verbindingsdoos		
B1	Electrode d'ionisation	Elettrodo d'ionizzazione	Electrodo de ionización	Ionisation electrode	Ionisationselektrode	Ionisatie-elektrode		
F4	Manostat gaz	Pressostato gas	Presostato de gas	Gas pressure switch	Gasdruckwächter	Gaspressostaat		
F6	Manostat d'air	Pressostato aria	Presostato de aire	Air pressure switch	Luftdruckwächter	Luchtpressostaat		
M1	Moteur du brûleur	Motore del bruciatore	Motor del quemador	Burner motor	Brennermotor	Brandermotor		
T2	Transformateur d'allumage	Transformatore d'accensione	Transformador de encendido	Ignition transformer	Zündtrafo.	Ontstekings-transformator		
Y10	Servomoteur	Servomotore	Servomotor	Servomotor	Stellantrieb	Servomotor		
Y13	Vanne gaz principale	Valvola principale gas	Valvula de gas principal	Gas valve burner side	Gasventil Brennerseitig	Hoofdafsluiter gas		
Y14	Vanne gaz 2ème allure	Valvola gas 2° stadio	Gas valvula 2a etapa	Gas valve 2nd stage	Gasventil 2.Stufe	Gasafsluiter 2.trap		
Y15	Vanne gaz de sécurité	Valvola sicurezza gas	Valvula de seguridad de gas	Gas safety valve	Sicherheitshauptgasventil	Veiligheidsafsluiter gas		
101	Ventilateur	Ventilatore	Ventilador	Blower	Ventilator	Ventilator		
103	Volet d'air	Serranda atia	Trampilla de aire	Air flap	Luftdosiertrommel	Luchtklep		
104	Régulateur de pression	Regolatore della pressione	Regulador de pression	Pressure regulator	Drukregler	Drukregelaar		
106	Filtre	Filtro	Filtro	Filter	Filter	Filter		
110	Injecteur gaz	Ugello gas	Inyector de gas	Gas injector	Gasinjektor	Gasinjector		
113	Grille d'aspiration	Scatola dell'aria	Caja de aire	Air box protection	Ansauggitter	Luchthuis		
119	Prise pression	Prisa pressione	Toma de presion	Pressure take-off	Messnippel	Meetnippel		





CUENOD
18 rue des Buchillons
F – 74100 Annemasse